



## C1000 DIGITAL THROUGH-THE-EARTH COMMUNICATION™ SYSTEM

### Overview

The C1000 Through-The-Earth Communication™ System uses advanced digital communications techniques and very low frequency transmission to provide reliable 2-way voice or data links through solid rock or concrete strata. The C1000 can be used to provide communications links from either the surface to below ground or between two below ground locations. It provides a point-to-point link that can be integrated with sensors, alarms or tracking systems, land-mobile radio systems, or other audio and <1kbps data applications.. The system provides a wide range of standard audio and data interfaces, allowing it to be connected to a wide variety of external devices and networks. Applications include mining, subways, tunnels, garages, and other below ground sites where wire based communications systems are expensive to install and maintain.

Vital Alert Communication Inc.  
302 John Street, Suite 4  
Thornhill ON L3T 6M8  
Canada

T +1 (647) 930-1534  
F +1 (647) 930-1539  
www.vitalalert.com

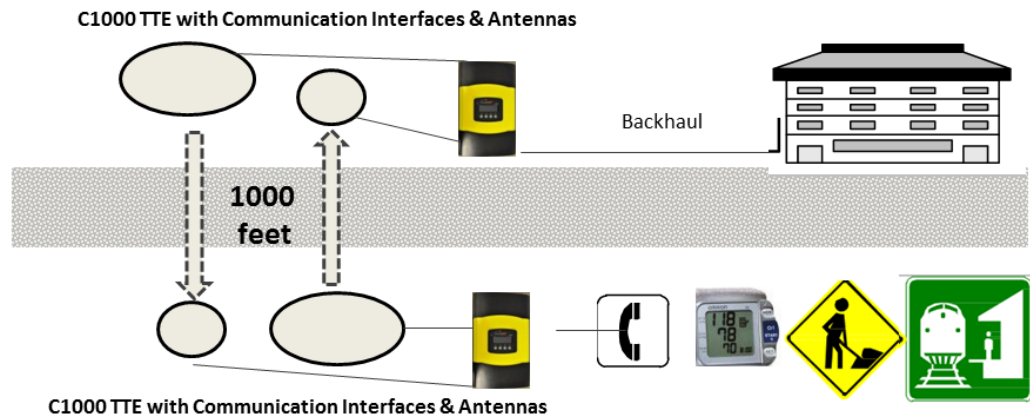

### The C1000 TTE System includes the following:

- 2 digital through-the-earth terminals
- 2 Transmit antennas
- 2 Receive antennas
- 2 Power supplies

### The C1000 Terminal has the following features:

- Operation in 2-9 kHz band.
- 1000 ft (voice) and 1500 ft (data) range through rock, soil, concrete etc.
- Digital “always on” wireless interface
- Fully automatic operation
- Supports 2-way voice and data communication
- Rugged and waterproof – rated IP-67





## ELECTRICAL SPECIFICATIONS

Operating frequency	2 to 9 kHz (unlicensed) band
Signal type	Digitally modulated magnetic field
Configuration	Web based with user API
Data throughput	1 kb/sec full duplex
Voice communications	1 circuit, half duplex (PTT)
Voice codec type	SPR (800 bpsec)
Noise filtering	Up to 20 dB 50/60 Hz harmonics
Power supply	+24V DC (external)
Power consumption	<10W standby, <200W at max output

---

## USER INTERFACES

Audio	Handset/headset (mic, ear, PTT)
Speaker output	2W max.
Remote data (isolated)	RS-485/RS-422
Local data (isolated)	Digital input/output, Relay (2x form C)
Display	VGA
Keyboard, etc.	(2) USB Host port (Type A)
	Bluetooth
Network/Configuration	Ethernet
	Wi-Fi (802.11g)

---

## ENVIRONMENTAL SPECIFICATIONS

The C1000 system is designed to operate in non-protected and underground environments. Basic environmental specifications are compliant with IEC standards as per ETS-300-019 Class 4.1 (telecommunications equipment in non weather-protected locations).

Temperature	-40 to +40C
Humidity	15 to 100% condensing
Vibration	2-9Hz: 3mm, 9-200Hz: 10m/s/s
Shock	250 m/s/s, 6 msec duration
Water, dust ingress	Rugged and waterproof, IP-55

---

## REGULATORY COMPLIANCE

The C1000 system complies with the following regulatory standards:

- FCC Part 15 Class A, RSS-210
- IEC/ULS/CSA/EN 60950-1
- RoHS Compliant
- IP-67 Compliant